

# CAETANO



## iTRABUS



2,9 m<sup>3</sup> (290 kg)

### DESTINATION: CAPACITY AND COMFORT

iTRABUS is the new minibus of Caetano, equipped with the latest Iveco chassis Euro 6.

Developed with a high level of comfort and outstanding quality, iTRABUS is the best solution for school transport or for the tourist segment. With a capacity up to 31 seats, iTRABUS main features are its high quality standards and the wide luggage compartment.



**CAETANOBUS**  
GRUPO SALVADOR CAETANO

Av. Vasco da Gama, 1410  
4431-956 Vila Nova de Gaia, Portugal  
Tel.: +351 227 867 016  
Fax: +351 227 867 171

[www.caetanobus.pt](http://www.caetanobus.pt)  
[sales@caetanobus.pt](mailto:sales@caetanobus.pt)  
Check CAETANO products on Youtube

## CAPACITY

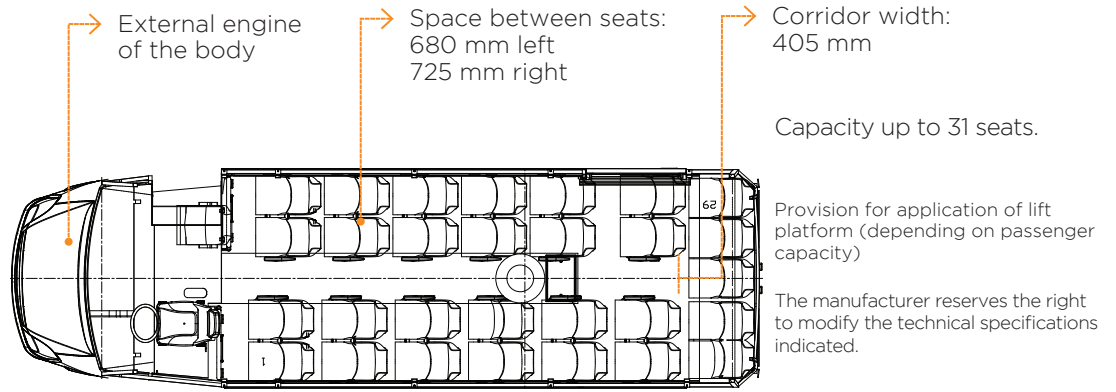

## DIMENSIONS

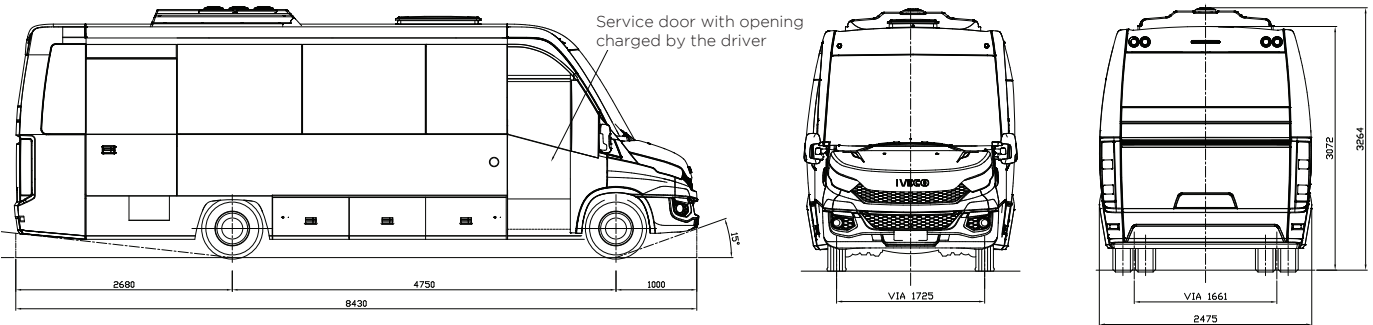

## EQUIPMENT

Standard

- Independent air conditioning for driver and guide
- Audiosystem
- Central heating with convectors
- Coloured double glazing
- Division part behind driver and guide seat
- First aid kit
- Microphone to the driver
- Padded seats washable napa
- Parking sensors in the bumpers
- Rearview camera
- Reclining seats with 3 fixation point seatbelts
- Service door with anti-squeeze system and opening by remote control
- 5-speed air conditioning for passenger

- Destination display
- Metallic paint
- Emergency door with provision to lift platform
- Seats footrest
- Folding table behind the seats
- LCD monitor 15"
- Leather or fabric seats
- Magazine holders behind the seats

Optional

## SPECIFICATION

ENGINE	
ENGINE	ENGINE F1C 180 CV 3.0 L EEV
TYPE	4-CYLINDERS IN-LINE, 16 VALVES
INJECTION	COMMON RAIL
CYLINDER	2998 cc
POWER	132,38 kW (180 CV) @ 2990 - 3500
MAX. TORQUE AT R/MIN.	400 Nm @ 1250 - 3000
FUEL	DIESEL
SUSPENSION	
FRONT	INDEPENDENT WITH TORSION BAR AND HYDRAULIC SHOCK ABSORBERS TELESCOPES
REAR	PNEUMATIC, PARABOLIC SPRINGS, ANTIROLL BAR AND SHOCK ABSORBERS
GEARBOX	
GEARBOX	AUTOMATIC ZF 8 SPEED + RV
BRAKES	
AXLES	SERVO-ASSISTED HYDRAULIC, ABS + ASR + EBD + ESP
FRONT BRAKES	SELF-COOLED DISKS
REAR BRAKES	SELF-COOLED DISKS
HANDBRAKE	MECHANICAL ON REAR WHEELS
ELECTRIC BRAKE	TELMA WITH CIRCUIT AND DIAGONALLY
WEIGHT	
GROSS VEHICLE WEIGHT	7,200 kg
TARA	5.500 kg